

Allgemeintoleranzen nach DIN 7168-m

bis 6	>6-30	>30-120	>120-400	400-1000
Nennm.	±0,1	±0,2	±0,3	±0,5
Radien	±1	±2	±4	
Winkel	±1°	±30'	±20'	±10'
				±5'

Schutzvermerk nach DIN ISO 16016 beachten

Beschriftungstext:

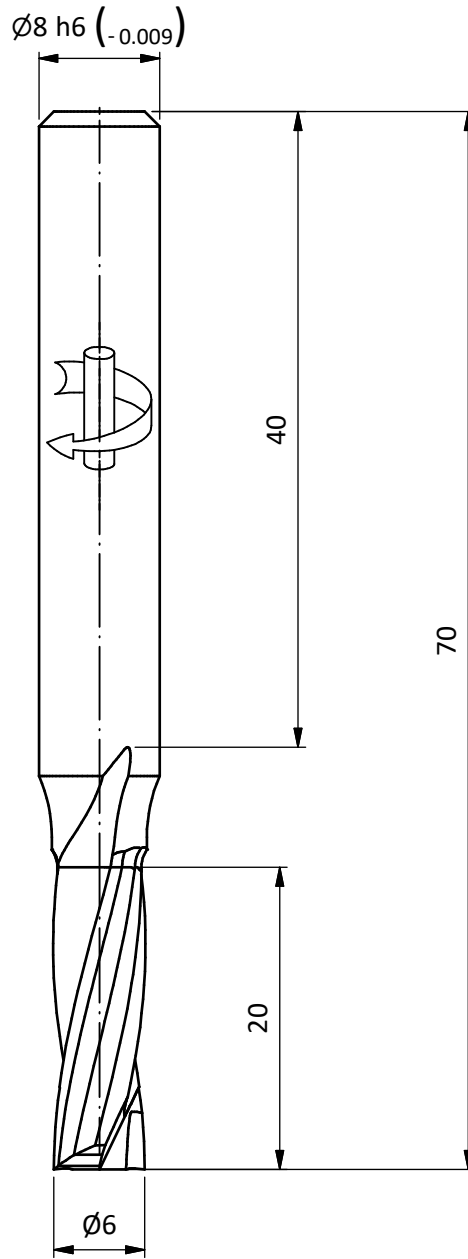

Zust.	Änderung	Datum	Name	Norm	

VHW-Schaftfräser
Z=2 Holzkraft

	Datum	Name	Masstab	NC-Programm
	22.11.2023	Mysliwicz	2 : 1	
Gez.			Material	20257-6-324-R
Gepr.			HW 04	
				Ersatz f.

